

RADIAL MILLING AND DRILLING HEAD

TYPE MURATEC

徑向鑽銑刀座 (90°)

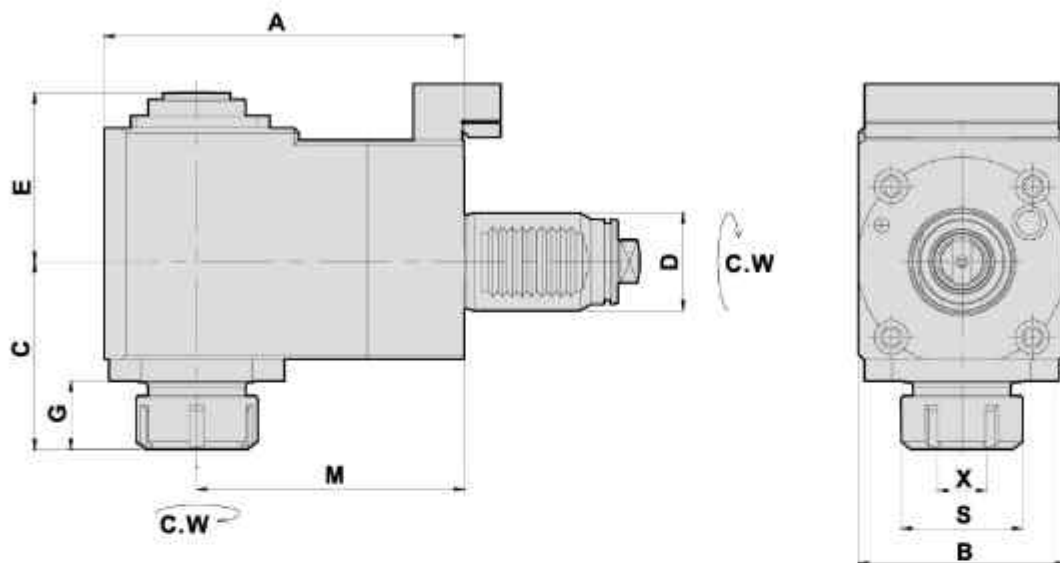

- To be used for collet DIN 6499
- External coolant supply
- Collet is not included

DIMENSIONS

Models	D	X Capacity	S	Maximum R.P.M.	A	B	C	E	G	M	Code No.	Order No.	(Kg) Weight
MT20	40	2-20 ER32	50	5000	148	85	79	69	30	110	2401FB-000	FR40-M-1809-32-110	9.5

AXIAL MILLING AND DRILLING HEAD

軸向鑽銑刀座 (0°)

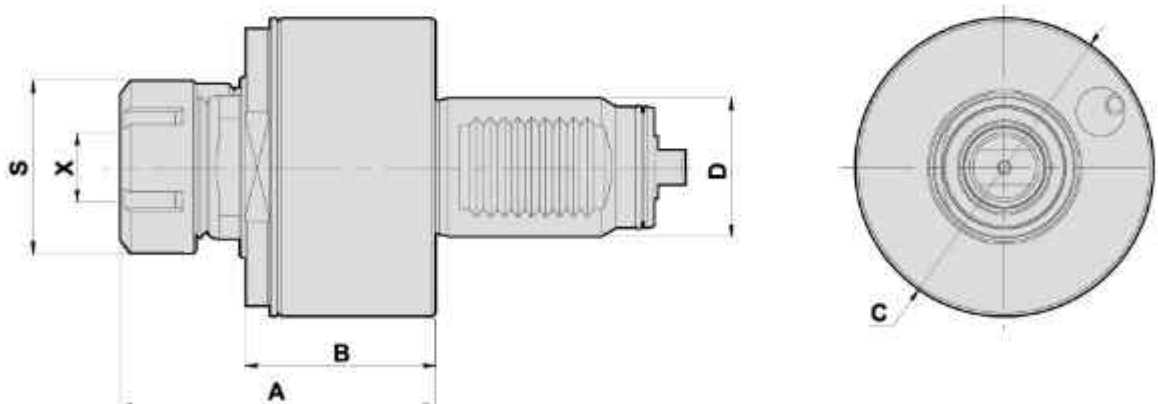

- To be used for collet DIN 6499
- External coolant supply
- Collet is not included

DIMENSIONS

Models	D	X Capacity	S	Maximum R.P.M.	A	B	C	Code No.	Order No.	(Kg) Weight
MT20 MT25	40	2-20 ER32	50	6000	92	56	86	1401FA-000	DA40-M-1809-ER32	3.1

RADIAL DRILLING AND MILLING HEAD OFFSET

TYPE MURATEC

徑向後縮式鑽銑刀座 (90°)

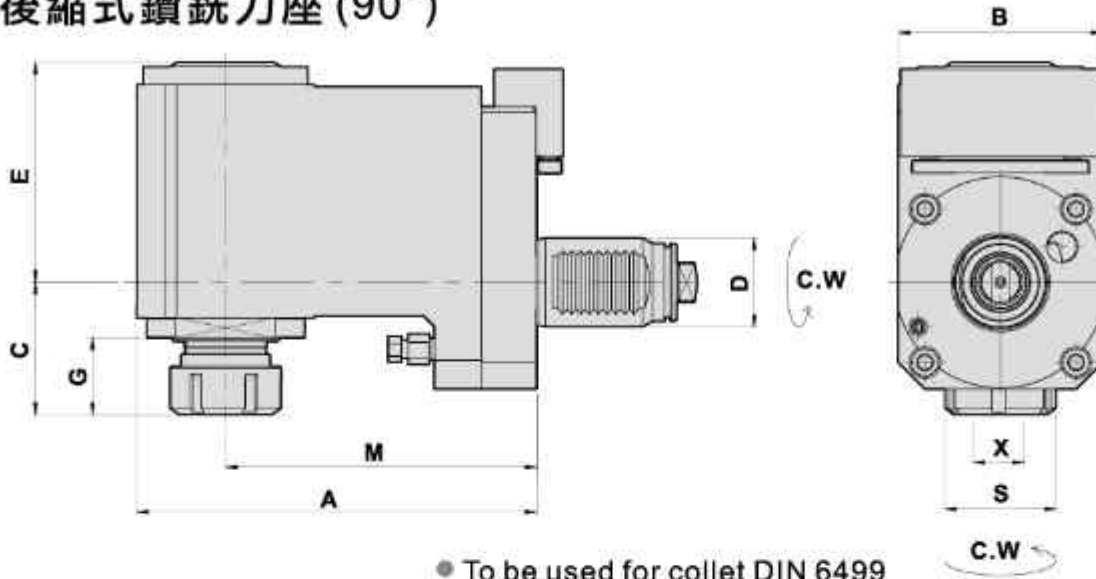

- To be used for collet DIN 6499
- External coolant supply
- Collet is not included

DIMENSIONS

Models	D	X Capacity	S	Maximum R.P.M.	A	B	C	G	E	M	Code No.	Order No.	(Kg) Weight
MT25	40	2-20 ER32	50	5000	180	92	60	35	99	140	2401FC-000	MT25-BR40-M-1809-32-140	14.1
MT20	40	2-20 ER32	50	5000	147	80	49	36	93	110	2401FG-000	BR40-M-1809-32-110	9.4
MT25	40	2-20 ER32	50	5000	180	92	61	38	105	140	*2401FL-000	TA-MT25-BR40-M-1809-32-140	14.3

*HEAVY CUTTING (重切削)

ANGULAR HEAD 萬向鑽銑刀座

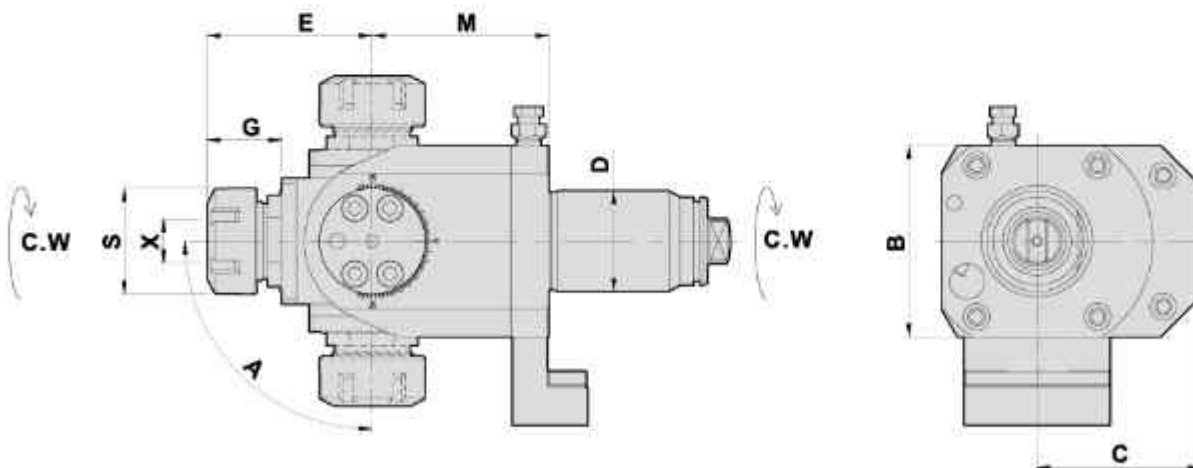

- To be used for collet DIN 6499
- External coolant supply
- Collet is not included

DIMENSIONS

Models	D	X Capacity	S	Maximum R.P.M.	A	B	C	G	E	M	Code No.	Order No.	(Kg) Weight
MT20 MT25	40	1-16 ER25	42	5000	±90°	76	65	29	65	70	1401FB-000	DA40-M-1809-25B	5.4

DOUBLE BORING BAR HOLDER

TYPE MURATEC

內孔雙向式刀座

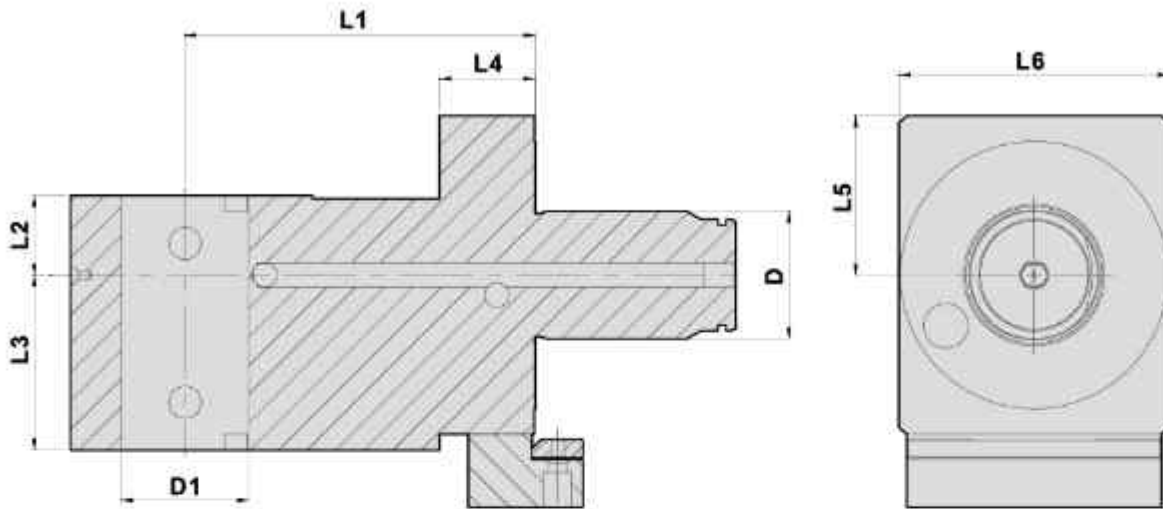

DIMENSIONS

● External, internal coolant supply

Models	D	D1	L1	L2	L3	L4	L5	L6	Code No.	Order No.	(Kg) Weight
MT20	40	40	110	25	55	30	50	85	308041-000	MT20-MU40-B40-110	8.3
MT25	40	40	140	25	55	30	40	86	308042-000	MT25-MU40-B40-140	9.7

TURNING HOLDER 外徑刀座

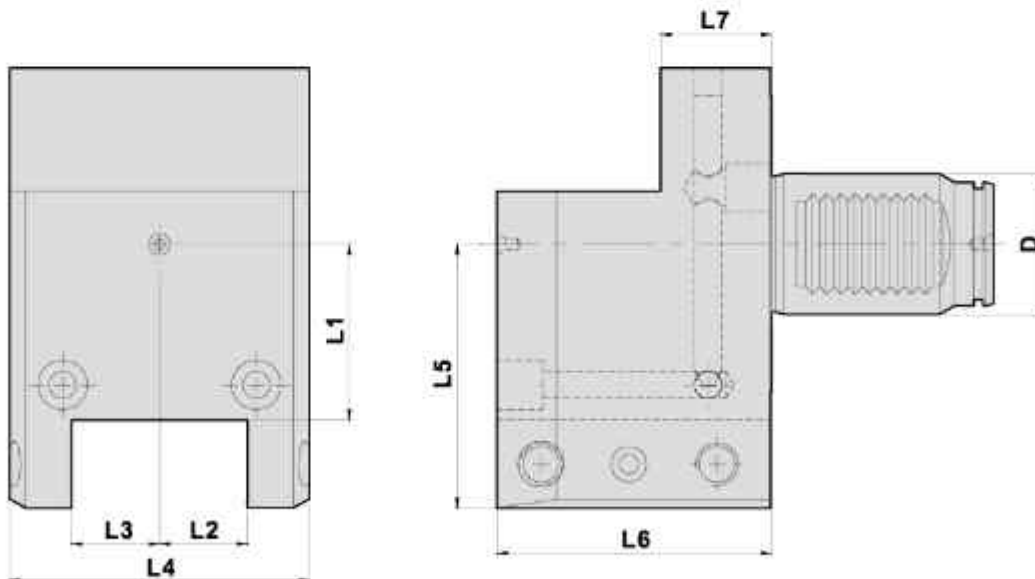

DIMENSIONS

● External coolant supply

Models	D	L1	L2	L3	L4	L5	L6	L7	Code No.	Order No.	(Kg) Weight
MT20	40	50	25	25	85	75	78	32	406041-000	MT20-MU40-25T	5.4
MT25	40	25	25	25	92	50	112	32	406042-000	MT25-MU40-25T	5.4

FACING HOLDER

TYPE MURATEC

端面刀座

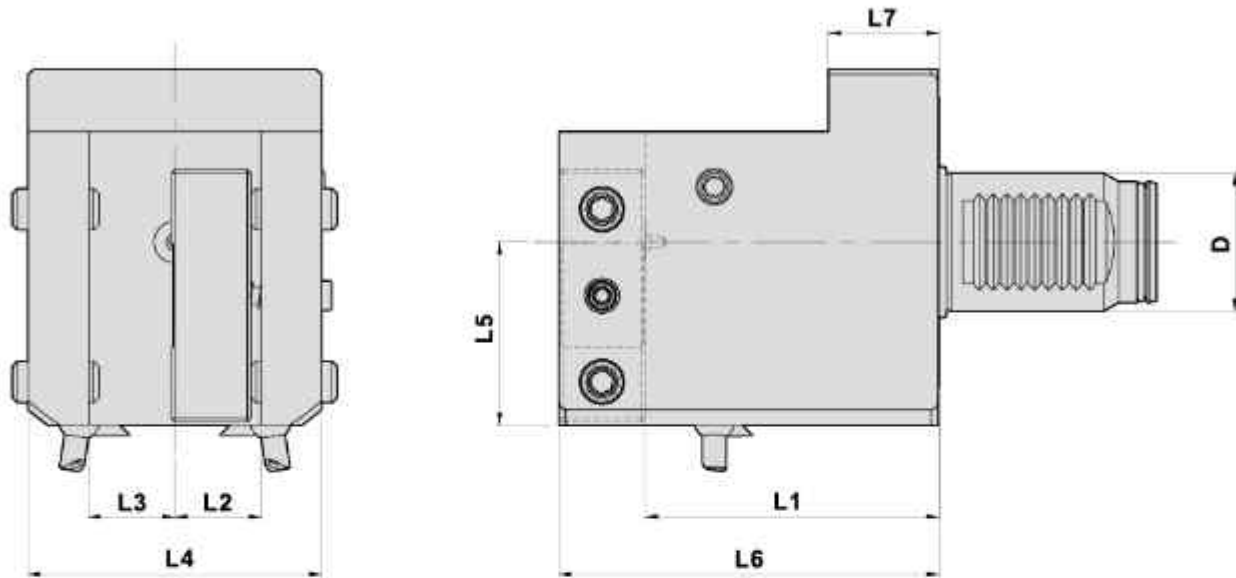

DIMENSIONS

• External, internal coolant supply

Models	D	L1	L2	L3	L4	L5	L6	L7	Code No.	Order No.	(Kg) Weight
MT20	40	85	25	25	85	53	110	32	506041-000	MT20-MU40-F25-110	6.6

AXIAL MILLING AND DRILLING HEAD OFFSET

TYPE MURATEC

軸向偏心鑽銑刀座 (0°)

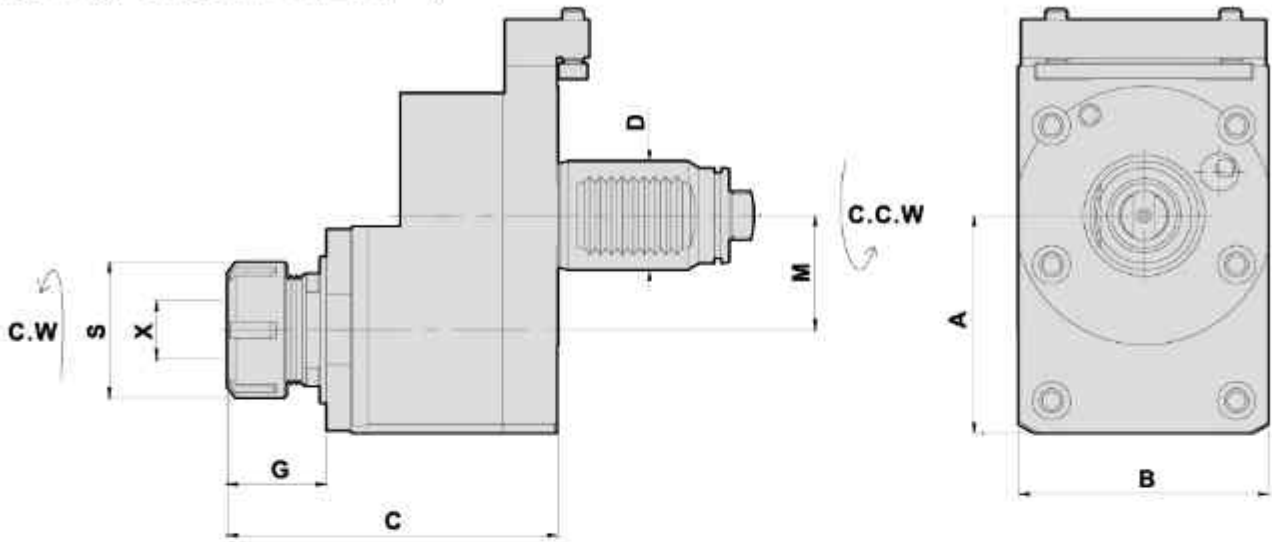

- To be used for collet DIN 6499
- External coolant supply
- Collet is not included

DIMENSIONS

Models	D	X Capacity	S	Maximum R.P.M.	A	B	C	G	M	Code No.	Order No.	(Kg) Weight
MT25	40	2-20 ER32	50	6000	80	92	122	37	42	1401FD-000	MT25-DA40-M-32-42	7.4

AXIAL MILLING AND DRILLING HEAD OFFSET-Quick-change Clamping System

軸向偏心快換鑽銑刀座 (0°)

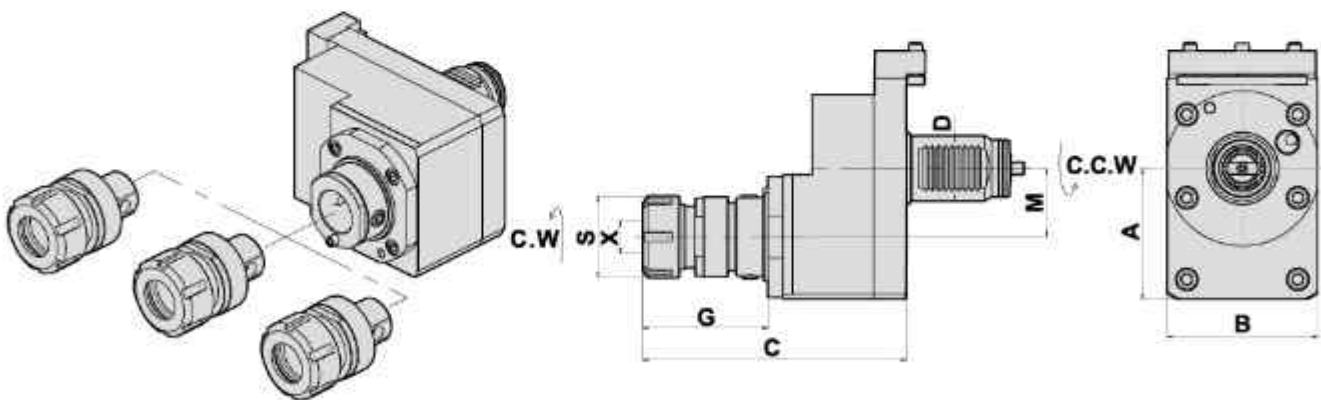

- To be used for collet DIN 6499
- External coolant supply
- Collet is not included

DIMENSIONS

Models	D	X Capacity	S	Maximum R.P.M.	A	B	C	G	M	Code No.	Order No.	(Kg) Weight
MT25	40	2-20 ER32	50	6000	80	92	162	76	42	1401FK-000	MT25-DA40-1809-32-42-QF	7.9

RADIAL MILLING AND DRILLING HEAD

TYPE MURATEC

徑向鑽銑刀座 (90°)

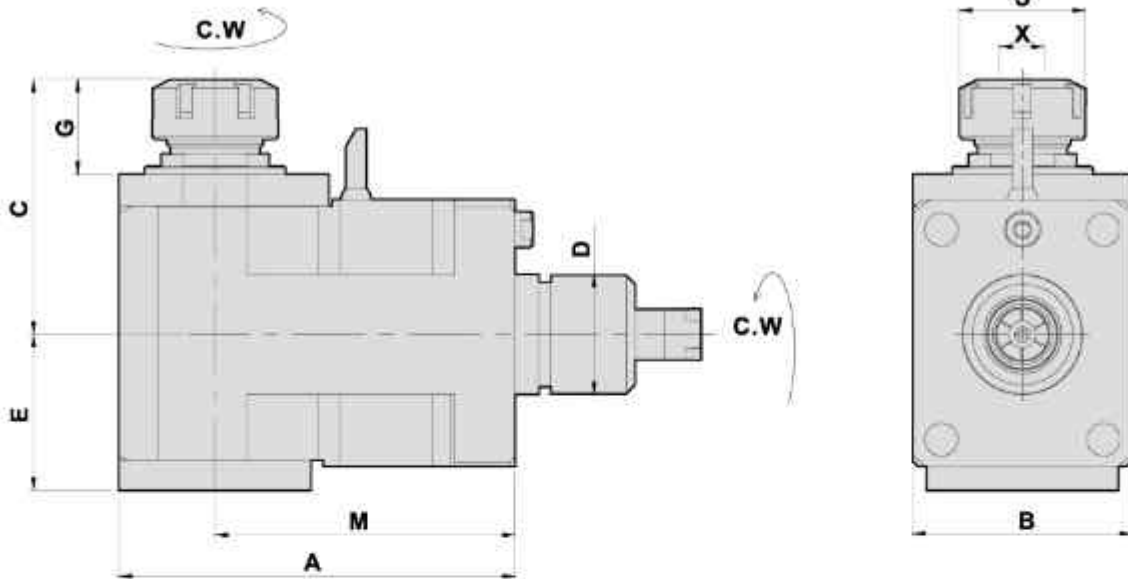

- To be used for collet DIN 6499
- External coolant supply
- Collet is not included

DIMENSIONS

Models	D	X Capacity	S	Maximum R.P.M.	A	B	C	E	G	M	Code No.	Order No.	(Kg) Weight
MT6	40	1-16 ER25	42	5000	132	73	85	53	32	100	240CFA-000	MT6-MDF40-25-100	5.9

AXIAL MILLING AND DRILLING HEAD

軸向鑽銑刀座 (0°)

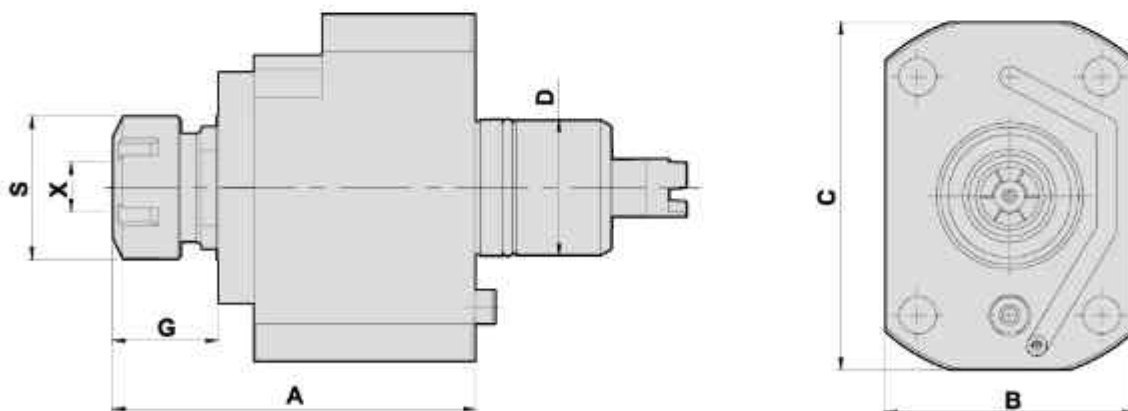

- To be used for collet DIN 6499
- External coolant supply
- Collet is not included

DIMENSIONS

Models	D	X Capacity	S	Maximum R.P.M.	A	B	C	G	Code No.	Order No.	(Kg) Weight
MT6	40	1-16 ER25	42	6000	107	73	102	31	140CFA-000	MT6-MDA40-ER25	3.9

RADIAL MILLING AND DRILLING HEAD OFFSET

TYPE MURATEC

徑向後縮鑽銑刀座 (90°)

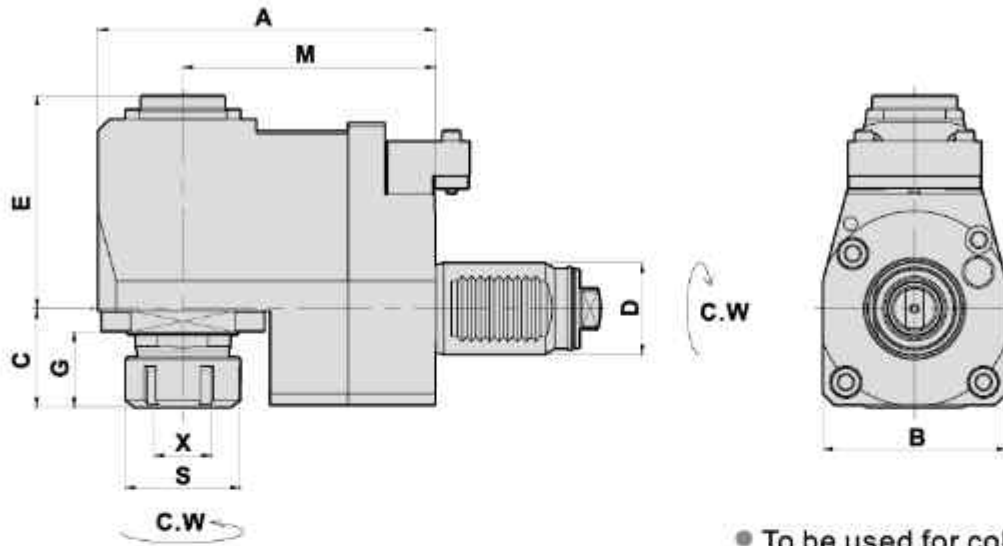

- To be used for collet DIN 6499
- External coolant supply
- Collet is not included

DIMENSIONS

Models	D	X Capacity	S	Maximum R.P.M.	A	B	C	E	G	M	Code No.	Order No.	(Kg) Weight
MT20	40	2-20 ER32	50	5000	147	80	49	93	36	110	2401FA-000	SH-BR40-M -1809-32-110	8.2

RADIAL MILLING AND DRILLING HEAD HEAVY CUTTING

徑向重切削鑽銑刀座 (90°)

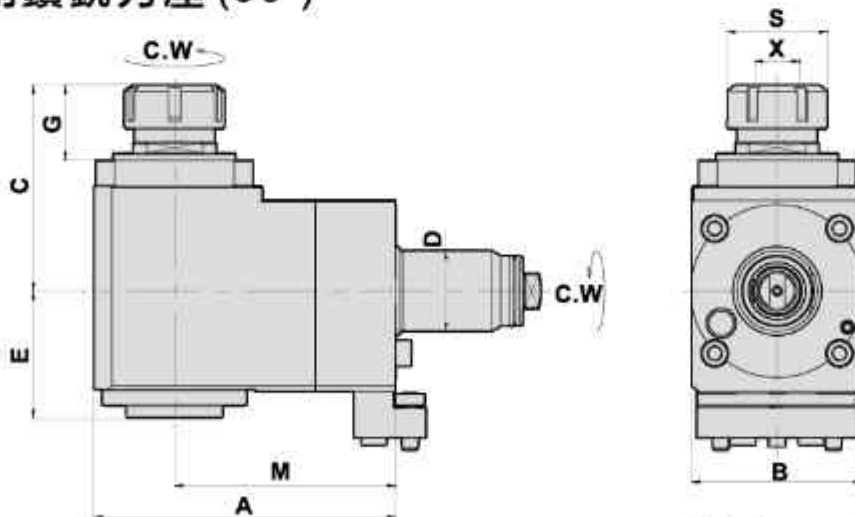

- To be used for collet DIN 6499
- External coolant supply
- Collet is not included

DIMENSIONS

Models	D	X Capacity	S	Maximum R.P.M.	A	B	C	E	G	M	Code No.	Order No.	(Kg) Weight
MT20	40	2-20 ER32	50	5000	150	85	103	63	37.5	110	2401FD-000	TA-FR40- 1809-32-110	11

AXIAL MILLING AND DRILLING HEAD Quick-change Clamping System

TYPE MURATEC

軸向快換鑽銑刀座 (0°)

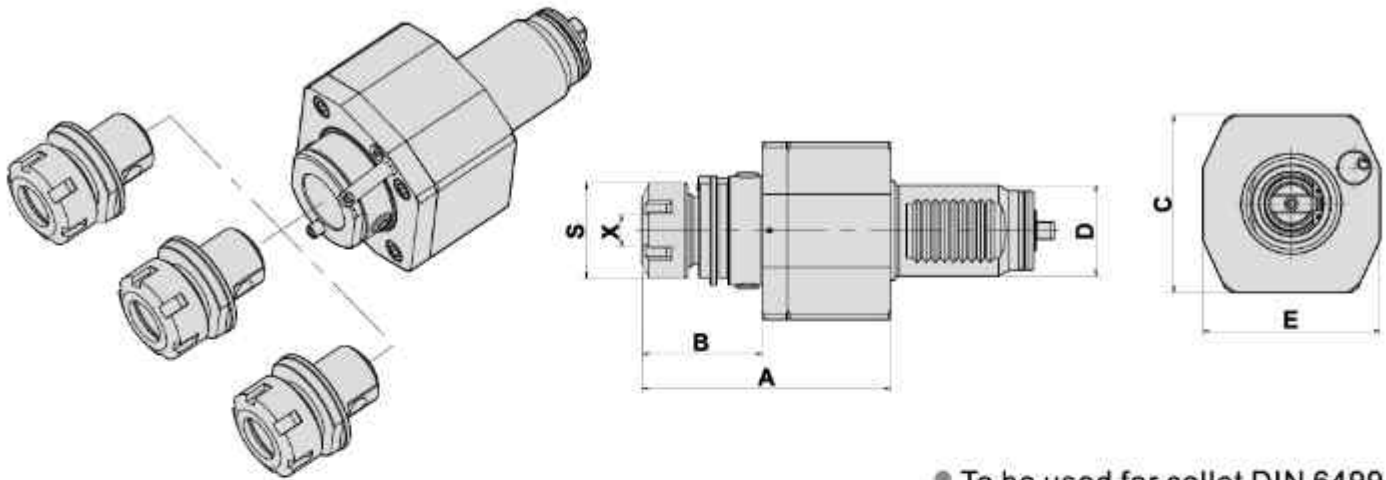

- To be used for collet DIN 6499
- External coolant supply
- Collet is not included

DIMENSIONS

Models	D	X Capacity	S	Maximum R.P.M.	A	B	C	E	Code No.	Order No.	(Kg) Weight
MT20 MT25	40	1-16 ER25	42	6000	110	53	78	78	1401FE-000	DA40-M-1809- ER25-QF	3.2

RADIAL MILLING AND DRILLING HEAD Quick-change Clamping System

徑向快換鑽銑刀座 (90°)

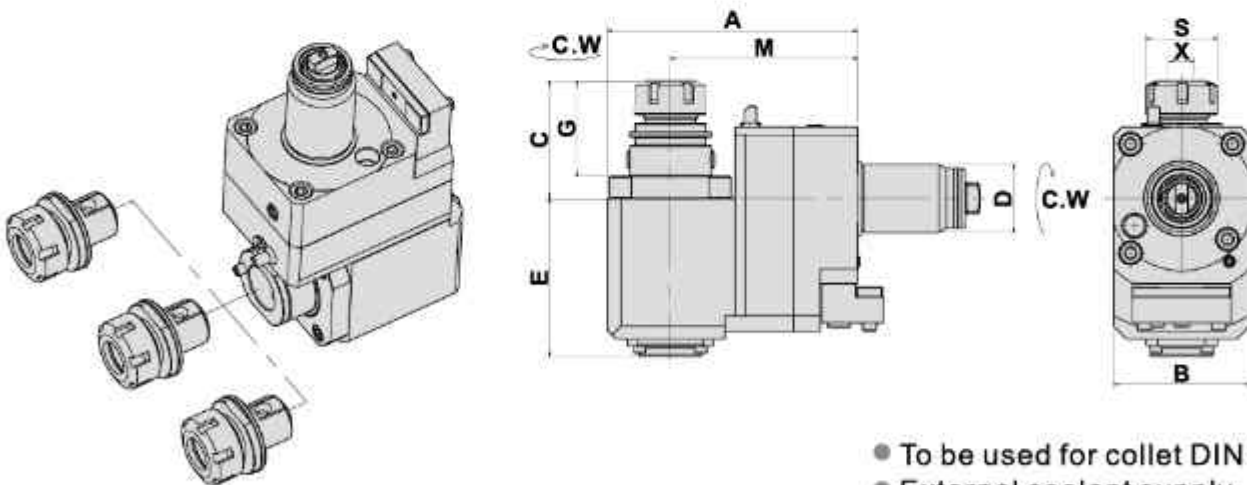

- To be used for collet DIN 6499
- External coolant supply
- Collet is not included

DIMENSIONS

Models	D	X Capacity	S	Maximum R.P.M.	A	B	C	E	G	M	Code No.	Order No.	(Kg) Weight
MT20	40	1-16 ER25	42	5000	147	80	69	93	56	110	2401FJ-000	BR40-M-1809- -25-110-QF	9.7
MT25	40	2-20 ER32	50	5000	180	92	100	99	76	140	2401FK-000	BR40-M-1809- -32-140-QF	14.6

**AXIAL MILLING AND DRILLING HEAD
DOUBLE HEAD, Y OFFSET**

TYPE MURATEC

軸向鑽銑刀座-雙頭Y軸偏心 (0°)

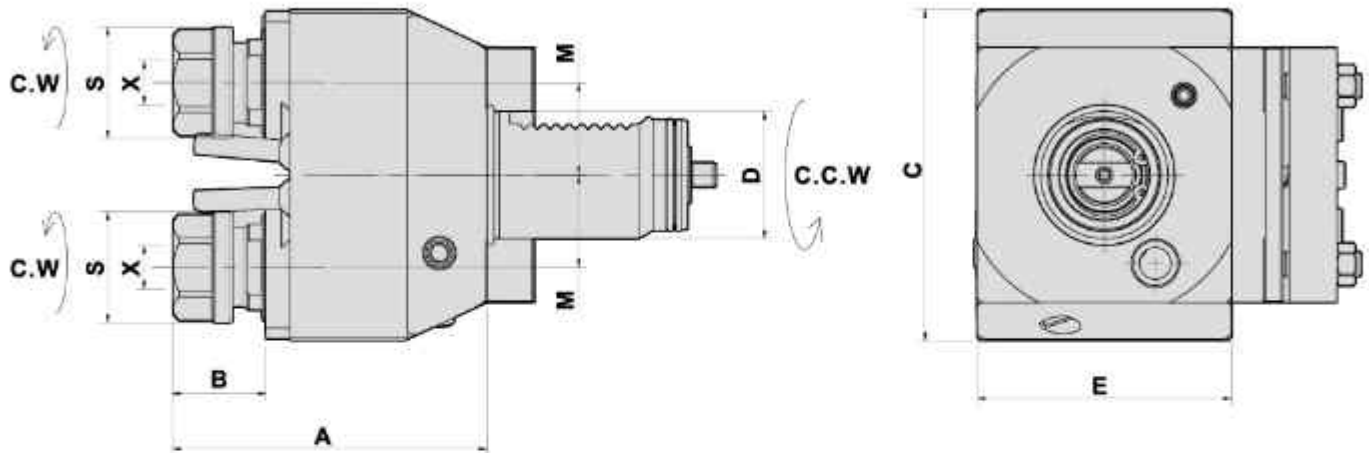

- To be used for collet DIN 6499
- External coolant supply
- Collet is not included

DIMENSIONS

Models	D	X Capacity	S	Maximum R.P.M.	A	B	C	E	M	Code No.	Order No.	(Kg) Weight
MT20 MT25	40	1-13 ER20	35	6000	99	29.3	104	80	29	1401FG-000	DA40-M- 1809-20DY	5.1

AXIAL MILLING AND DRILLING HEAD

TYPE MURATEC

軸向鑽銑刀座 (0°)

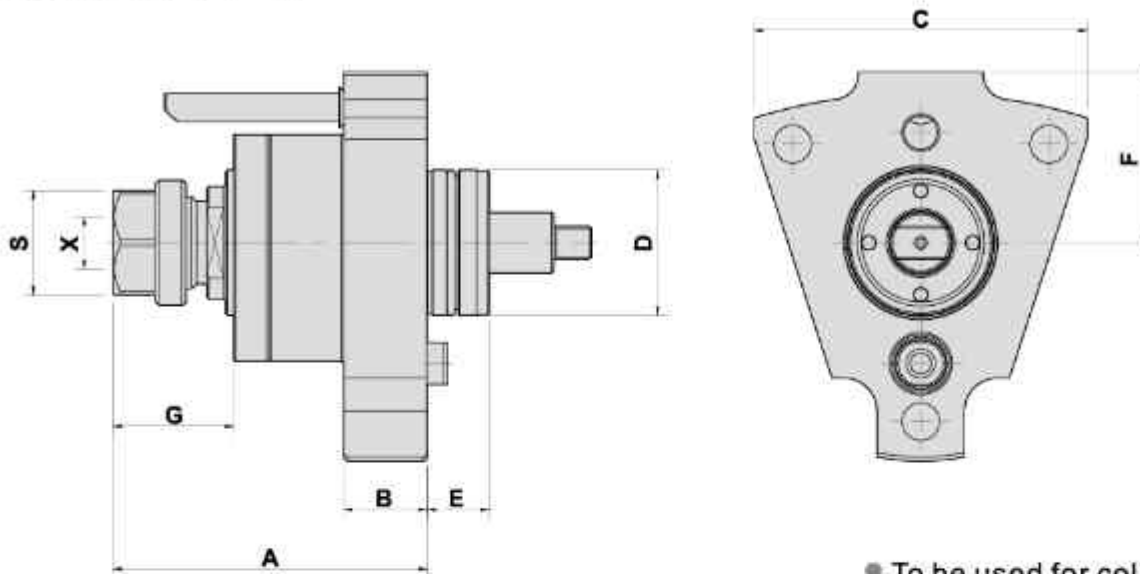

- To be used for collet DIN 6499
- External coolant supply
- Collet is not included

DIMENSIONS

Models	D	X Capacity	S	Maximum R.P.M.	A	B	C	E	F	G	Code No.	Order No.	(Kg) Weight
MT20-MW	35	1-10 ER16	30	6000	75.5	20	80	15	41	29	1351FA-000	MW40-DA35 -ER16	1.5

RADIAL MILLING AND DRILLING HEAD

徑向鑽銑刀座 (90°)

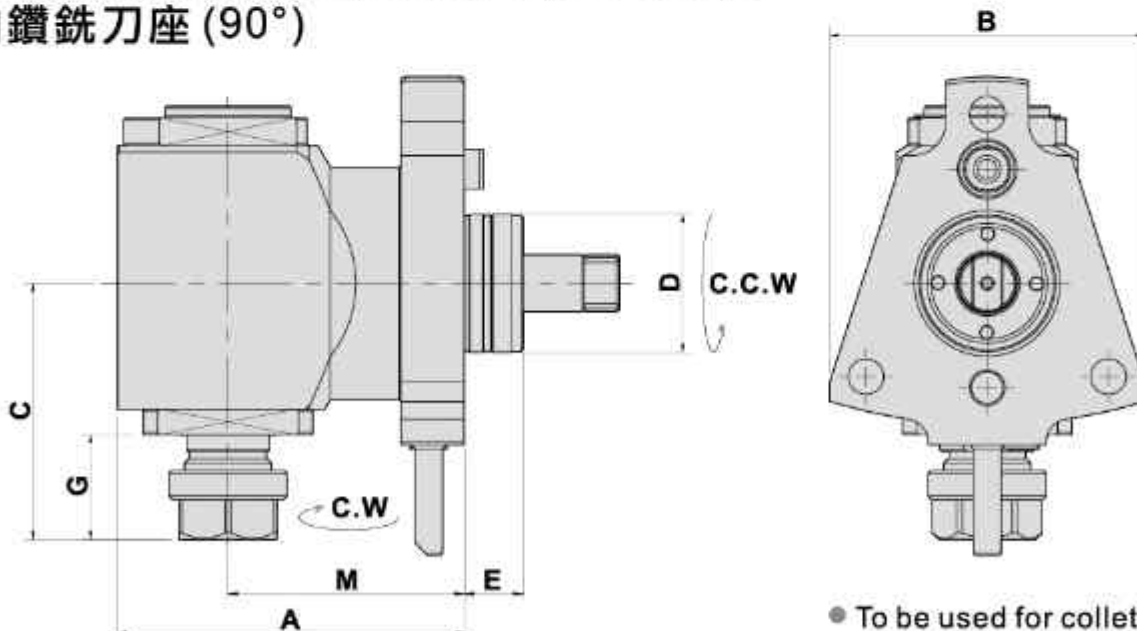

- To be used for collet DIN 6499
- External coolant supply
- Collet is not included

DIMENSIONS

Models	D	X Capacity	S	Maximum R.P.M.	A	B	C	E	G	M	Code No.	Order No.	(Kg) Weight
MT20-MW	35	1-10 ER16	30	5000	88	80	65	45	26.5	60	2351FA-000	MW40-DF35 -16-60	2.4

AXIAL MILLING AND DRILLING HEAD

TYPE MURATEC

軸向鑽銑刀座 (0°)

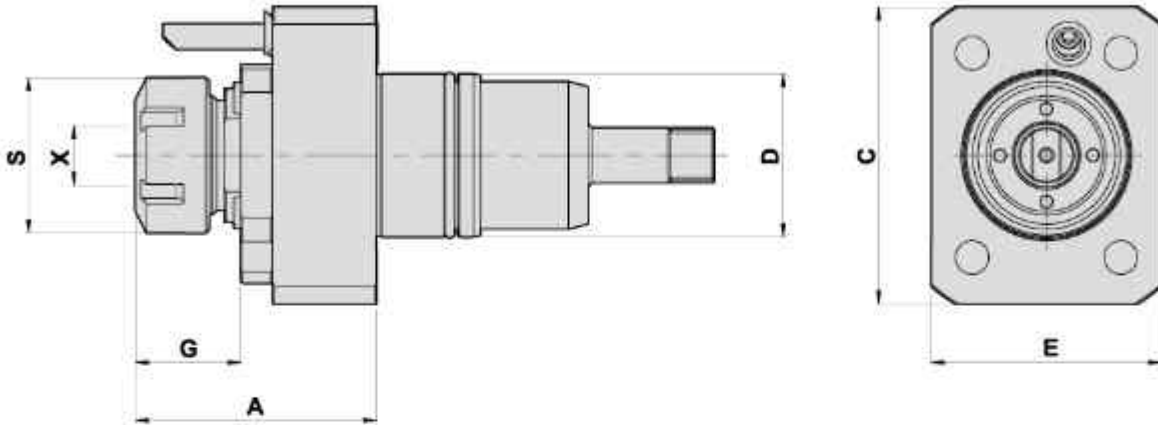

- To be used for collet DIN 6499
- External coolant supply
- Collet is not included

DIMENSIONS

Models	D	X Capacity	S	Maximum R.P.M.	A	C	E	G	Code No.	Order No.	(Kg) Weight
MT100	44	1-16 ER25	42	6000	65	80	62	29	1441FA-000	MT100-DA44-ER25	2.1
MT100	44	1-13 ER20	35	6000	64.5	80	62	28	1441FD-000	MT100-DA44-ER20	1.9

AXIAL MILLING AND DRILLING HEAD

軸向銑削刀座 (0°)

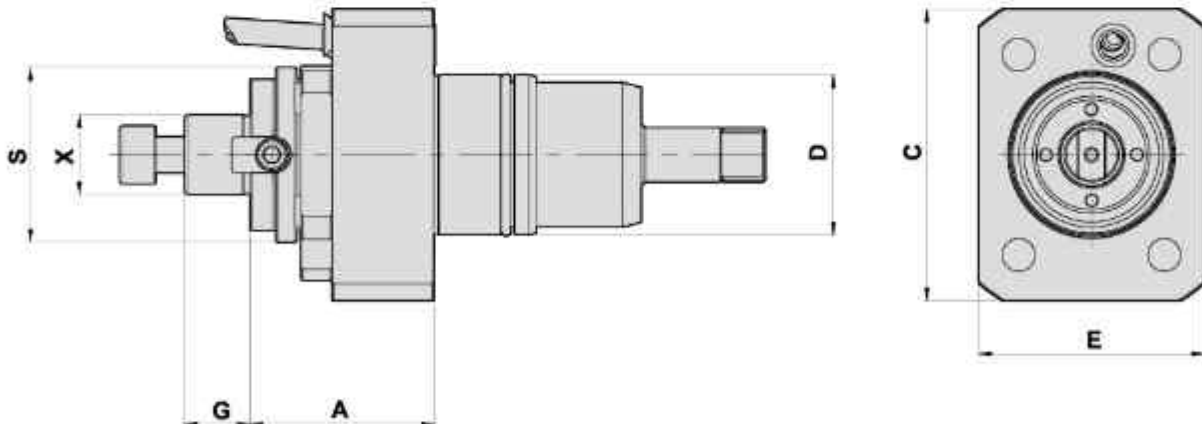

- To be used for collet DIN 6499
- External coolant supply
- Collet is not included

DIMENSIONS

Models	D	X	S	Maximum R.P.M.	A	C	E	G	Code No.	Order No.	(Kg) Weight
MT100	44	22	48	6000	50.5	80	62	18	1441FB-000	MT100-DA44-22C	1.9

RADIAL MILLING AND DRILLING HEAD

TYPE MURATEC

徑向鑽銑刀座(90°)

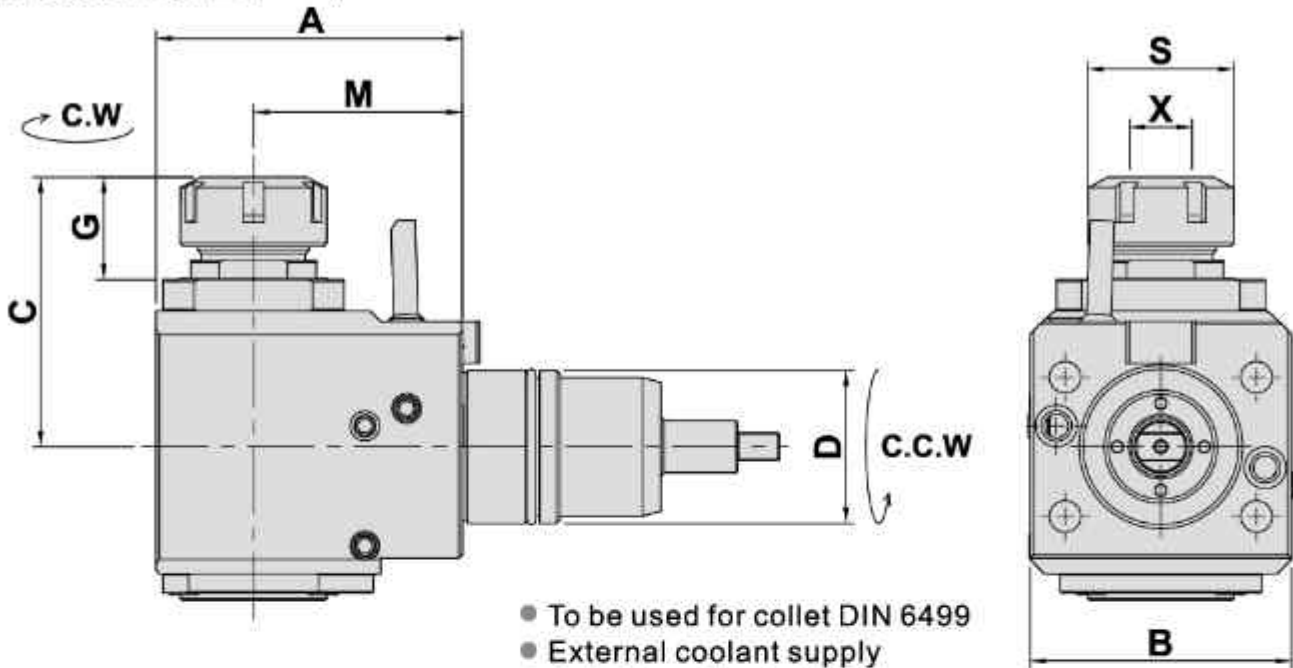

- To be used for collet DIN 6499
- External coolant supply
- Collet is not included

Models	D	X Capacity	S	Maximum R.P.M.	A	B	C	G	M	Code No.	Order No.	(Kg) Weight
MT100	44	1-16 ER25	42	5000	88	75	77.5	29.5	60	2441FA-000	MT100-DF44-25-60	4.4

RADIAL MILLING AND DRILLING HEAD

徑向鑽銑刀座(90°)

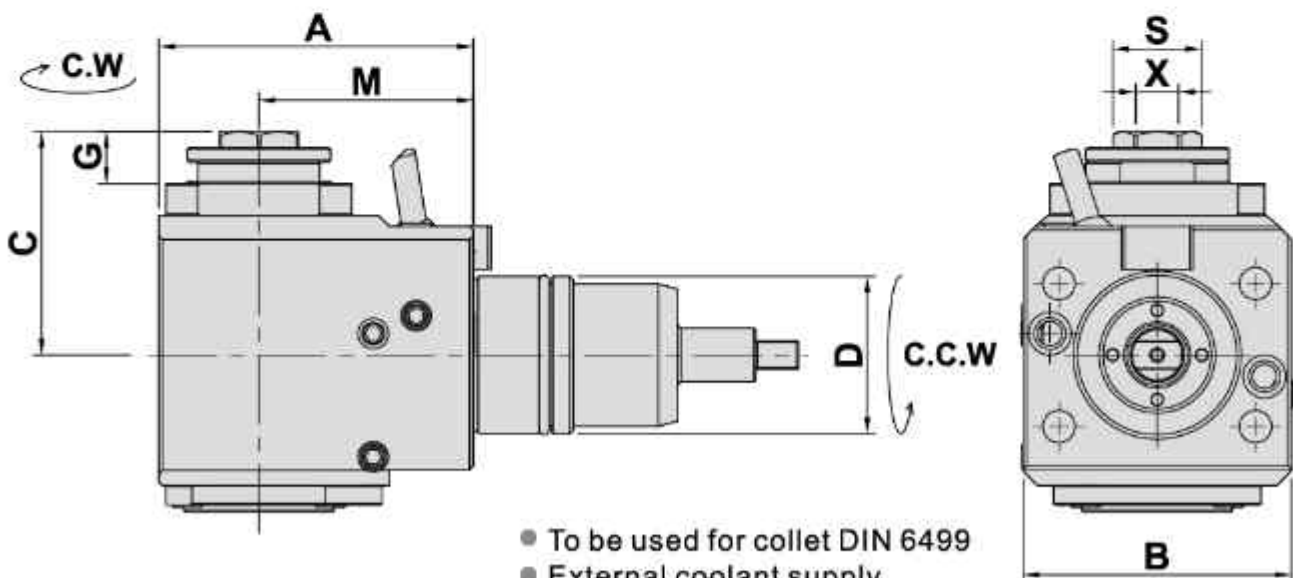

- To be used for collet DIN 6499
- External coolant supply
- Collet is not included

Models	D	X Capacity	S	Maximum R.P.M.	A	B	C	G	M	Code No.	Order No.	(Kg) Weight
MT100	44	1-13 ER20A	25.8	5000	88	75	62.5	14.5	60	2441FB-000	MT100-DF44-20A-60	4.3

RADIAL MILLING AND DRILLING HEAD

TYPE MURATEC

徑向鑽銑刀座(90°)

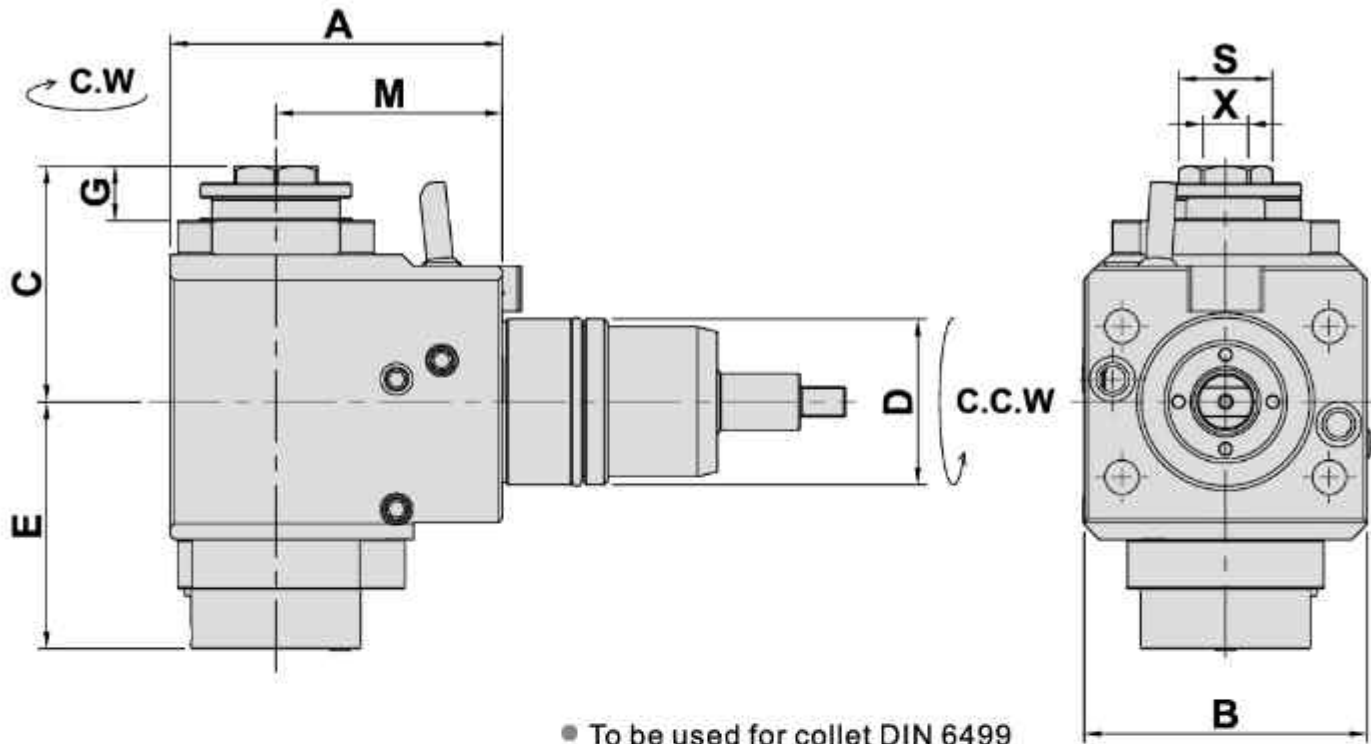

- To be used for collet DIN 6499
- Internal coolant supply: 50bar 中心出水
- Collet is not included

Models	D	X Capacity	S	Maximum R.P.M.	A	B	C	E	G	M	Code No.	Order No.	(Kg) Weight
MT100	44	1-13 ER20A	25.8	5000	88	75	62.5	65.5	14.5	60	2441FC-000	MT100-CW-DF44-20A-60	4.6

TURNING HOLDER

TYPE MURATEC

外徑刀座

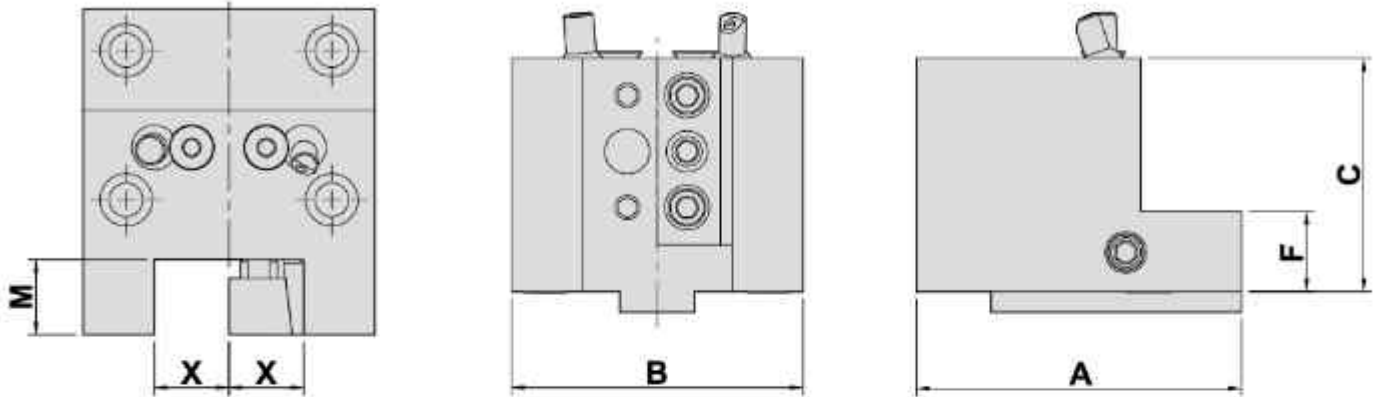

DIMENSIONS

● External coolant supply 外部出水

Models	X	A	B	C	F	M	Code No.	Order No.	(Kg) Weight
MT100	20	87	78	62.5	21.5	20	405043-000	MT-100-C20-62-RL	2.5

CUTTING HOLDER

切斷刀座

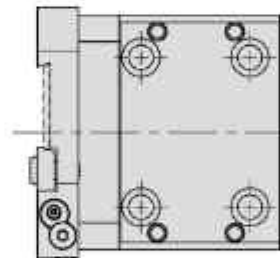
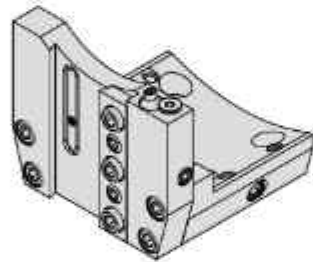

Note:
Insert is not included

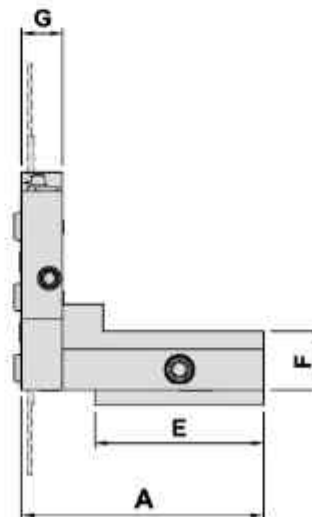
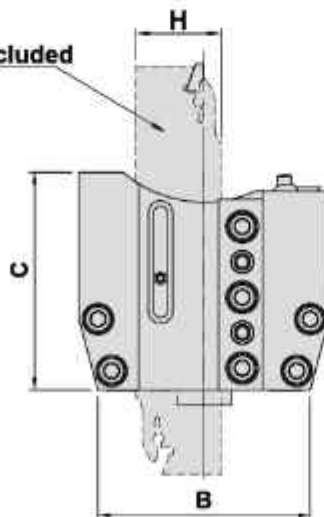

DIMENSIONS

● External coolant supply 外部出水
● Internal coolant supply 内部出水

Models	A	B	C	E	F	G	H	Code No.	Order No.	(Kg) Weight
MT100	89	78	80	62	21.5	15	32	706041-000	MT100-R25-80-H	1.6